

MONOXIVENT[®]

Source Capture Systems

Operation and Maintenance Manual

Underground Exhaust System



MONOXIVENT - SOURCE CAPTURE SYSTEMS

1306 Mill St., Rock Island, IL 61201
877-608-4383 - info@monoxivent.com
monoxivent.com

Underground Duct Construction Standards

- 1.** Dig trench depth to allow for minimum distance from the top of the pipe of 11" to finished floor, to a maximum distance from the top of the piece of pipe of 17" to finished floor. (The saddle body is adjustable. The saddle tube has a clamp band attached to hold outlet to saddle.) In some cases the saddle may not be adjustable. In this instance, the trench depth will be the distance from the bottom of the pipe to the floor flange.
- 2.** Install pipe and fittings according to local codes and industry standards. Use proper sealant at all joints. If joints utilize angle rings use appropriate sealant or closed cell gasket material.
- 3.** Pipe and fittings should be pitched, in the direction of airflow, back to a sump or pit where the pipe emerges from underground. Consult local codes for any special requirements.
- 4.** Following the building plan, locate and mark location for each floor outlet assembly.
- 5.** Cut hole in pipe. Hole to be slightly larger than the opening in the saddle tap. Remove any burrs or rough edges that may come in contact with flex hose assembly.
- 6.** Center saddle over hole and fasten pipe making sure that the saddle is inclined in the proper direction. It is recommended that the saddles be attached to the pipe with full circle clamps on each end. Screws or rivets that protrude in to the pipe may catch on the flex hose assembly causing damage to the hose and/or making hose storage difficult. Use appropriate joint sealant to seal saddles to main duct.
- 7.** Back fill around pipe and saddle assembly. Consult local codes for any special requirements.
- 8.** Adjust floor flange to proper level. Position and/or support using wooden stakes if necessary.
- 9.** You are now ready to pour the finished floor. Care must be taken so as not to disturb floor outlets while pouring and finishing the floor. (For example, don't allow them to be run over with the cement truck or wheelbarrows.)

Underground Duct Construction Standards

S3.41 This installation standard is applicable to ducts placed in or beneath concrete floors or in areas free from vehicle traffic.

S3.42 Materials shall conform to the project specifications.

S3.43 Ducts shall be located as shown on the contract drawings.

S3.44 The duct contractor shall provide:

- a)** Proper assembly of the duct, including connections and sealing as prescribed;
- b)** Verification of the undamaged condition of the duct before enclosure with fill or encasement.
- c)** Anchorage for the duct, if any.
- d)** Notices of requirements for successive placements of fill, if any.
- e)** Precautions against use of powered vibrators in placing concrete on or around ducts.
- f)** Witnessing of backfill or encasement.
- g)** Temporary protection of openings in ducts.



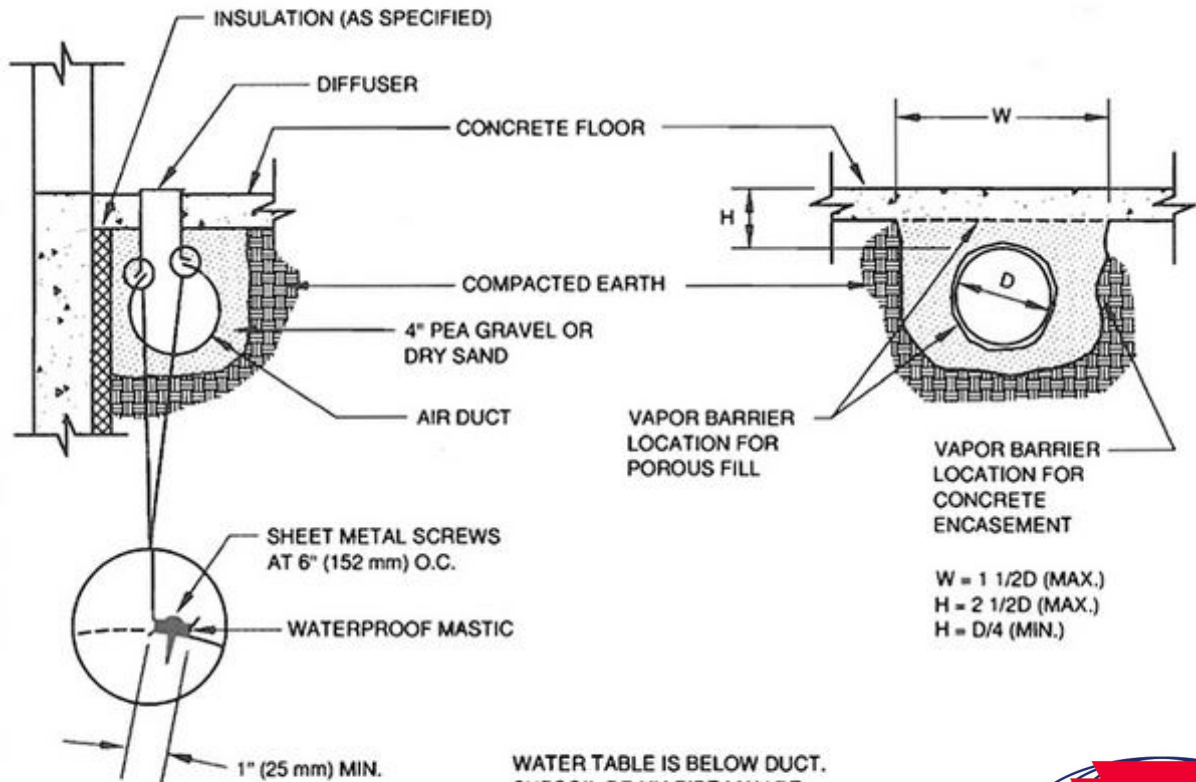
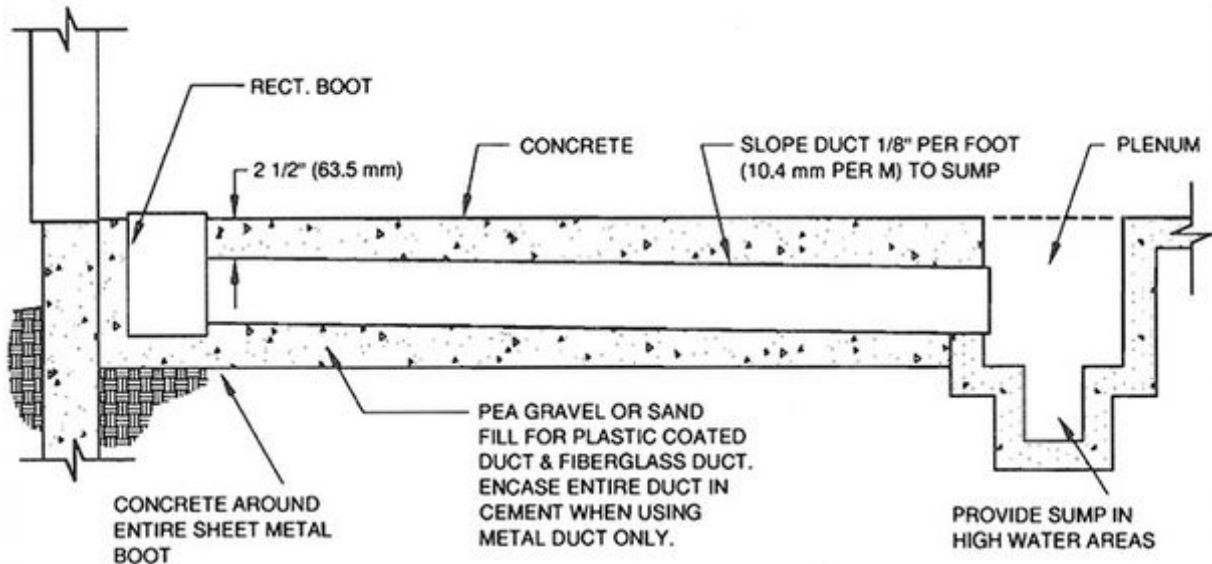

WATER TABLE IS BELOW DUCT. SUBSOIL DRAIN PIPE MAY BE NEEDED BELOW DUCT IN SOME AREAS.

THIS ILLUSTRATION IS A DESIGN GUIDE.



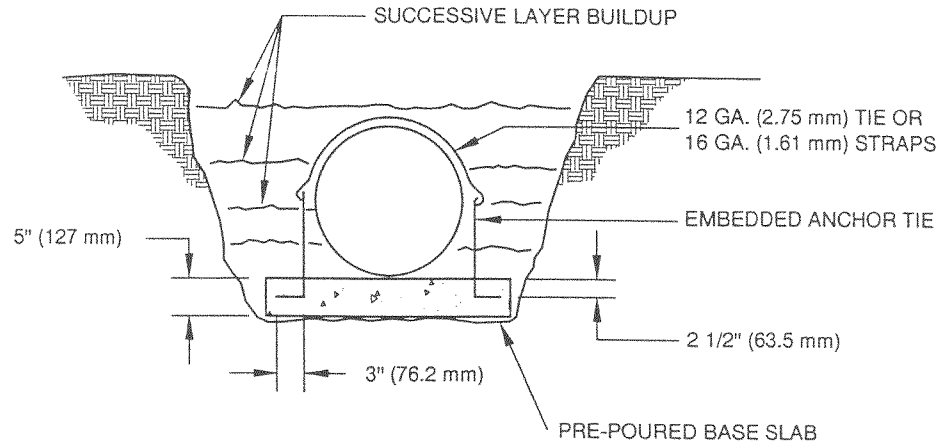

PRECAUTION!

THREE STAGE PLACEMENT OF CONCRETE IS ADVISABLE TO AVOID DAMAGE AND REDUCE DANGER OF FLOTATION. CONCRETE SHOULD NEVER BE DUMPED ON THE DUCT; COVER SHOULD BE MOVED Laterally OVER THE DUCT.

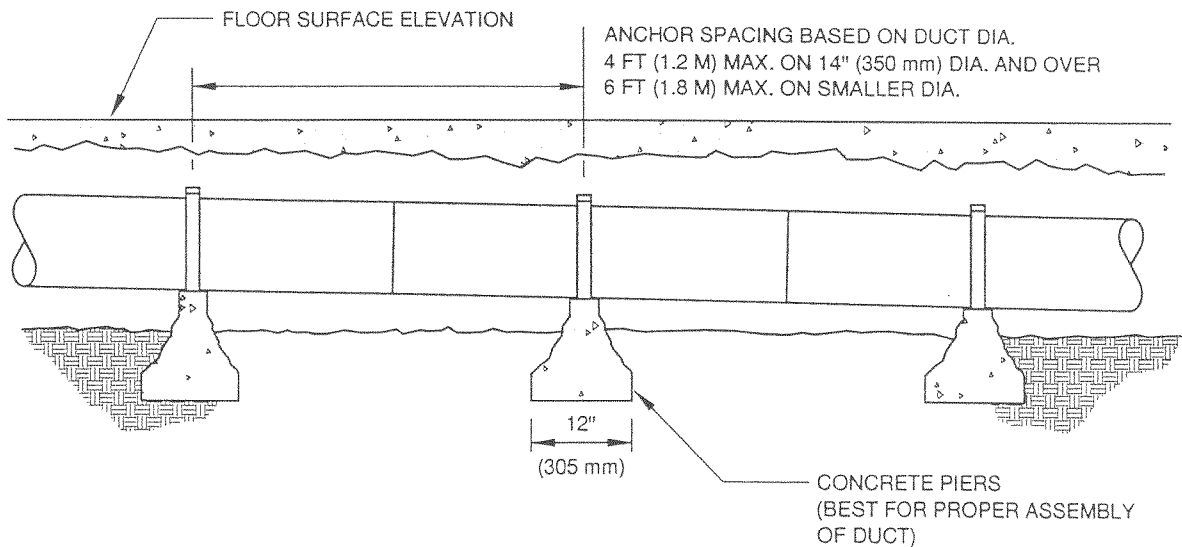

TYPICAL ANCHORAGE OF DUCTS TO BE ENCASED IN CONCRETE



Commentary

Materials commonly used for this application include; galvanized steel, vinyl chloride-coated steel, and stainless steel. Glass fiber-reinforced resin, asbestos, cement, tile, and other nonmetal ducts are also used. Ducts are not generally deemed to be or required to be waterproof. Ducts should always be above the water table. The designer should carefully evaluate the exposure to moisture or round water and require vapor barriers, sumps, porous fill, and subsoil drainage pipe as necessary. CSI Specification 02410 provides useful references for subsoil damage. The top of drain tile should be below the bottom of the duct.

Corrosion resistance is an important characteristic of both in-slab and under-slab ducts. The Portland Cement Association has guidelines for protection of metals in contact with concrete. ASHRAE's *Systems Handbook* addresses the corrosion of materials in soil environments.

The strength of round ducts makes them the preferred shape for underground application. Round duct wall thicknesses in these standards are generally acceptable for below-grade installation. Ribbed or corrugated styles have additional crushing strength. Temporary internal supports can be appropriate at times. Ducts should have continuous bedding.

Ducts to be embedded in concrete are subject to floating and they must be restrained. The first pour should be the base support for the duct and anchors should be included. Twelve gage (2.68mm) wire, 16gage (2.75mm) straps, or other appropriate ties should be specified for hold-down.

Ducts buried in sand or pea gravel are not known to float. Porous fill and earth fill should not be dumped directly on ducts in trenches. Fill should be firmly but not heavily tamped under and around the duct. The first foot of fill should be shovelled on top of the duct. Fill should not contain stones larger than 2" (51mm).



• **MODELS:** 23816 - FOR 3" HOSE; 23818 - FOR DUAL 3" HOSE; 23817 - FOR 4" HOSE; 23819 - FOR 5" HOSE; 23820 - FOR 6" HOSE •

SIDE VIEW

* LAY FLAT DOOR & FLOOR FLANGE

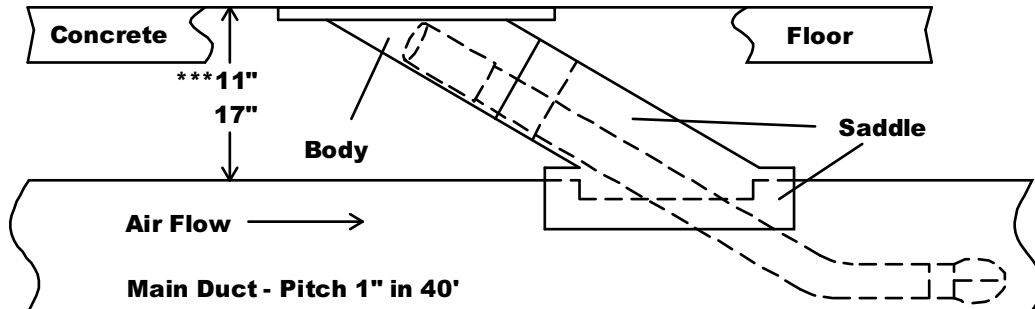

NOTES:

1. This dimension can be increased or decreased
2. Extension sleeves will be required to reach heights over 17".

TOP VIEW

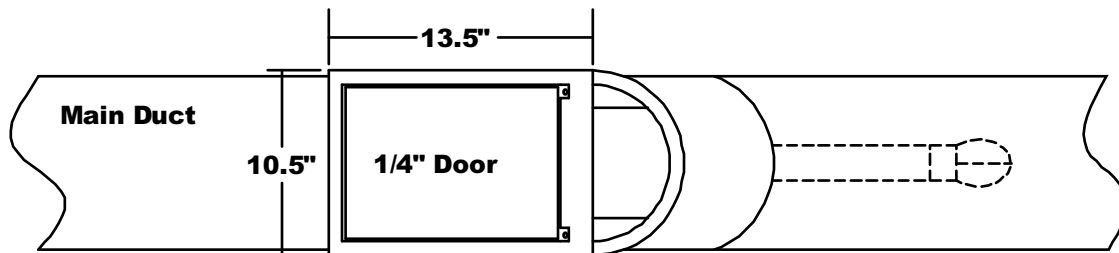

PRODUCT FEATURES:

- DOOR -** 1/4", 4-way Structural Solid Steel Plate - 9" x 11" Zinc Coated
- FLOOR FLANGE -** 14-Gauge Stamped Steel Plate Zinc Coated
- BODY -** 20-Gauge 304 Stainless Steel
- SADDLE -** 20-Gauge 304 Stainless Steel