

MONOXIVENT[®]

Source Capture Systems

Operation and Maintenance Manual

Centrifugal Blowers Series BI



MONOXIVENT - SOURCE CAPTURE SYSTEMS

1306 Mill St., Rock Island, IL 61201
877-608-4383 - info@monoxivent.com
monoxivent.com

INSTALLATION, OPERATION, AND MAINTENANCE MANUAL

This publication contains the installation, operation and maintenance instructions for standard units of the Monoxivent *Series BI-Centrifugal Blowers*.

Carefully read this publication prior to any installation or maintenance procedure.

Monoxivent catalog, Series BI, provides additional information describing the equipment, fan performance, available accessories, and specification data.

For additional safety information, refer to AMCA publication 410-96, *Safety Practices for Users and Installers of Industrial and Commercial Fans*.

All of the publications listed above can be obtained from Monoxivent by phoning 309/794-1000; by FAX at 309/794-1020; or by e-mail at info@monoxivent.com.

For information on special equipment, contact Monoxivent Customer Service Department at 309/794-1000.

Receiving and Inspection

Carefully inspect the fan and accessories for any damage and shortage immediately upon receipt of the fan.

- Turn the wheel by hand to ensure it turns freely and does not bind.
- Inspect dampers (if supplied) for free operation of all moving parts.
- Record on the *Delivery Receipt* any visible sign of damage.

WARNING

This unit has rotating parts. Safety precautions should be exercised at all times during installation, operation, and maintenance. ALWAYS disconnect power prior to working on fan.

Handling

Lift the fan by the base or lifting eyes. **Never lift by the shaft, motor, or housing.**

Storage

If the fan is stored for any length of time prior to installation, completely fill the bearings with grease or moisture-inhibiting oil (refer to Lubricants on page 5). Rotate the wheel several revolutions every three to five days to keep a coating of grease on all internal bearing parts.

Store the fan in its original crate and protect it from dust, debris and the weather.

Outdoor Storage

To maintain good working condition of the fan when it is stored outdoors, follow the additional instructions below.

- Coat the shaft with grease or a rust preventative compound.

- Wrap bearings for weather protection.
- Cover the inlet and outlet to prevent the accumulation of dirt and moisture in the housing.
- Periodically rotate the wheel and operate dampers (if supplied).
- Periodically inspect the unit to prevent damaging conditions.

Personal Safety

Disconnect switches are recommended. Place the disconnect switch near the fan in order that the power can be swiftly cut off in case of an emergency, and in order that maintenance personnel are provided complete control of the power source.

Installation

Motor Installation

Most motors are shipped mounted on the fans with belts and drives installed. However, extremely heavy motors and drives are shipped separately. These motors and drives will require field installation. Please refer to pages 4.

Foundation

This fan requires a strong, level foundation of reinforced poured concrete. A correctly designed concrete foundation provides the best means for mounting floor units. The foundation's size is determined by fan size and arrangement, motor size and position, and the specific location of the installation.

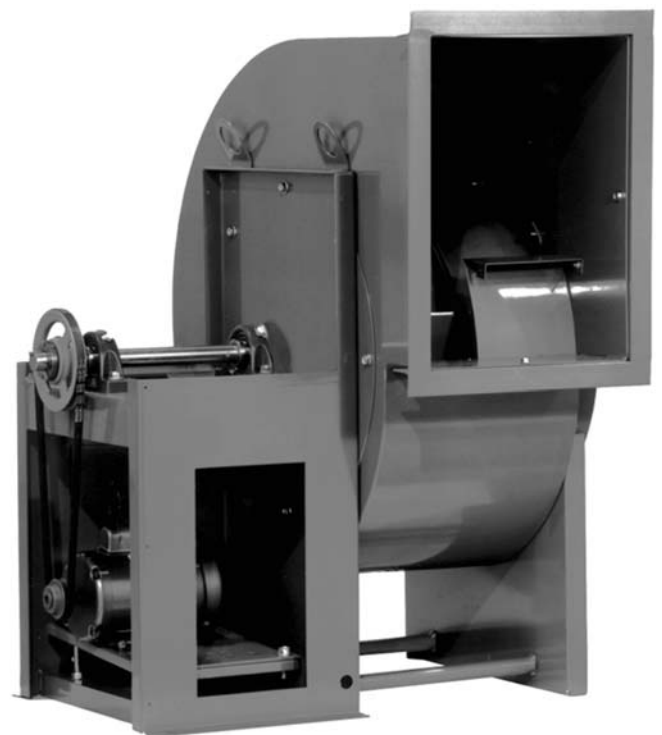

Series BI

Foundation continued

Use the following guidelines to calculate foundation size:

- The overall dimensions of the foundation should extend at least 6 inches beyond the outline of the fan and its motor.
- The weight of the foundation should be 2 to 3 times the weight of the unit and its motor.

Isolation

Isolation Base

To prevent vibration and noise from being transferred to the building isolators are recommended. Arrangement 10 fans above size 270 require isolation rails. Please consult factory for isolation of arrangement 9 fans due to the potential of uneven loading caused by the motors and drives. Isolators should be located between the fan system and the support structure.

Note

Although a certain amount of vibration is inherent in operating centrifugal fans, extreme vibration is a serious problem that may cause structural and mechanical failure.

Ceiling Mounted Isolators

Some applications require fan systems designed for floor mounting to be suspended from ceiling supports. In such cases, all fans should be installed on either rails or bases in the classical orientation. Typically, these systems are hung from the corners by rods, which include isolation hangers of either spring or rubber-in-shear design. ***Under no circumstances is the fan to be inverted and hung by its base angles.***

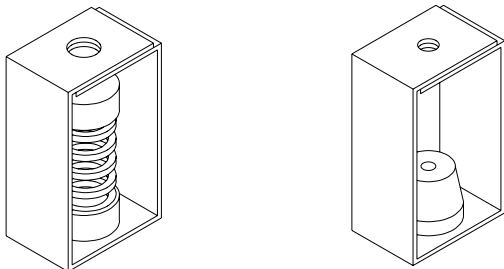

Ceiling Mounted Spring Isolator Rubber-In-Shear Ceiling Isolators

Figure 1 - Ceiling Mount Isolators

Floor Mounted Spring Isolators

- Mount fan and motor on isolation base (if supplied).
- Elevate fan (or isolation base) to operating height and insert blocks to hold in position.
- Position isolators under the fan and vertically align by inserting leveling bolt through mounting holes in the fan or the base. The isolator must be installed on a level surface.
- Adjust the isolators by turning the leveling nut counter clockwise several turns at a time alternately on each

isolator until the fan weight is transferred onto the isolators and the fan raises uniformly off the blocks. Then remove the blocks.

- Turn lock nut onto leveling bolt and secure firmly in place against the top of the mounting flange or frame.
- Secure isolators to mounting surface.

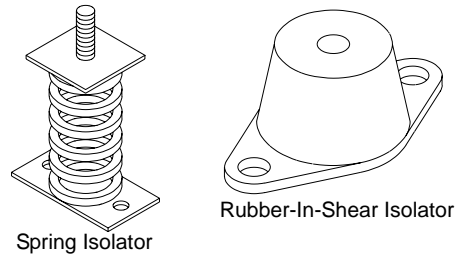

Figure 2 -Floor Mount Isolators

Floor Mounted Rubber-In-Shear (RIS) Isolators

- Mount fan and motor on an isolation base (if supplied).
- Elevate fan to provide room to insert isolators between the base and foundation and block in position.
- Position isolators under fan and secure bolts.
- Remove blocks and allow fan to rest on floor. Isolators must be installed on a level surface (leveling should not be required).
- Secure isolators to mounting surface.

Duct Installation

Efficient fan performance relies on the proper installation of inlet and discharge ducts. Be sure your fan conforms to the following guidelines.

Non-Ducted Inlet Clearance

If your fan has an open inlet (no duct work), the fan must be placed 1 fan wheel diameter away from walls and bulkheads.

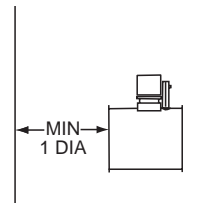

Free Discharge

Avoid a free discharge into the plenum. This will result in lost efficiency because it doesn't allow for a static regain.

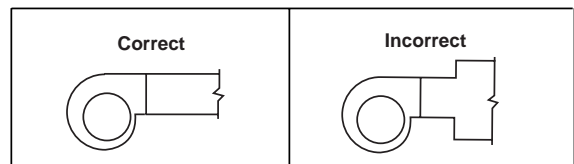

Free Discharge

Inlet Duct Turns

For ducted inlets, allow at least 3 fan wheel diameters between duct turns or elbows and the fan inlet.

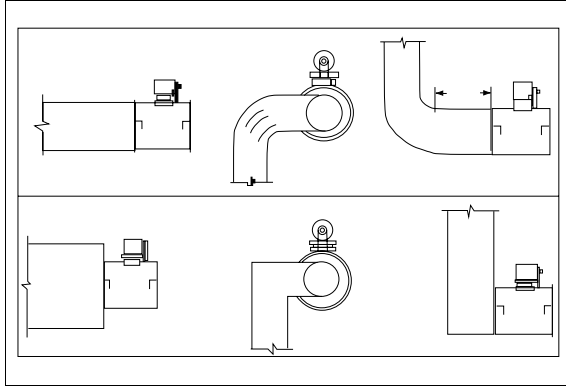

Discharge Duct Turns

Where possible, allow 3 duct diameters between duct turns or elbows and the fan outlet. Refer to figure above.

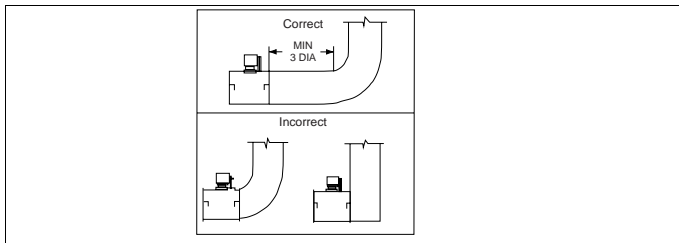

Discharge Duct Turns

Wheel-to-Inlet Clearance

The correct wheel-to-inlet clearance is critical to proper fan performance. This clearance should be verified before initial start-up since rough handling during shipment could cause a shift in fan components. Refer to wheel/inlet drawing for correct overlap.

Adjust the overlap by loosening the wheel hub and moving the wheel along the shaft to obtain the correct value.

A uniform radial gap (space between the edge of the cone and the edge of the inlet) is obtained by loosening the inlet cone bolts and repositioning the inlet cone.

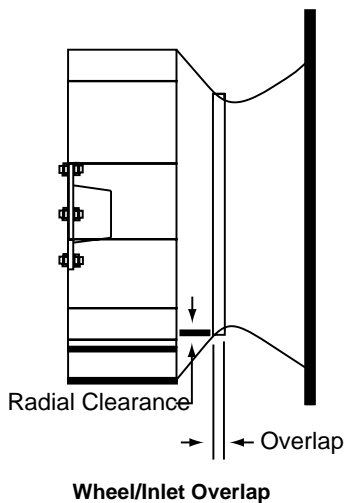

Wheel/Inlet Overlap

Size	Overlap
100	
120	
135	
150	5/8"
165	
180	
195	
210	
225	3/4"
245	
270	
300	
330	1"
365	
402	
445	
490	
540	1-1/4"
600	
660	
730	

Wiring Installation

All wiring should be in accordance with local ordinances and the National Electrical Code, NFPA 70. Ensure the power supply (voltage, frequency, and current carrying capacity of wires) is in accordance with the motor nameplate.

Lock off all power sources before unit is wired to power source.

Leave enough slack in the wiring to allow for motor movement when adjusting belt tension. Some fractional motors have to be removed in order to make the connection with the terminal box at the end of the motor. To remove motor, remove bolts securing motor base to power assembly. Do not remove motor mounting bolts.

Units with Arrangement 10 have a hole provided at the base of the bearing pedestal to accommodate wiring.

Personal Safety

Disconnect switches are recommended. Place the disconnect switch near the fan in order that the power can be swiftly cut off in case of an emergency, and in order that maintenance personnel are provided complete control of the power source.

Follow the wiring diagram in the disconnect switch and the wiring diagram provided with the motor. Correctly label the circuit on the main power box and always identify a closed switch to promote safety (i.e., red tape over a closed switch).

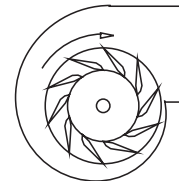

Airfoil

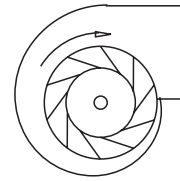

Backward Inclined

Wheel Rotation

Test the fan to ensure the rotation of the wheel is the same as indicated by the arrow marked Rotation.

115 and 230 Single Phase Motors

Fan wheel rotation is set correctly at the factory. Changing the rotation of this type of motor should only be attempted by a qualified electrician.

208, 230, and 460, 3 Phase Motors

These motors are electrically reversible by switching two of the supply leads. For this reason, the rotation of the fan cannot be restricted to one direction at the factory. See Wiring Diagrams above for specific information on reversing wheel direction.

Do not allow the fan to run in the wrong direction. This will overheat the motor and cause serious damage. For 3-phase motors, if the fan is running in the wrong direction, check the control switch. It is possible to interchange two leads at this location so that the fan is operating in the correct direction.

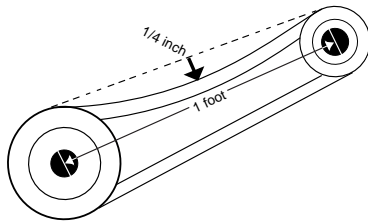

Figure 3

Belt and Pulley Installation

Belt tension is determined by the sound the belts make when the fan is first started. Belts will produce a loud squeal which dissipates after the fan is operating at full capacity. If the belt tension is too tight or too loose, lost efficiency and possible damage can occur.

Do not change the pulley pitch diameter to change tension. This will result in a different fan speed than desired.

- Loosen motor plate adjustment nuts on L-bolts and move motor plate in order that the belts can easily slip into the grooves on the pulleys. Never pry, roll, or force the belts over the rim of the pulley.
- Slide the motor plate back until proper tension is reached. For proper tension a deflection of approximately 1/4" per foot of center distance should be obtained by firmly pressing the belt. Refer to *Figure 3*.
- Lock the motor plate adjustment nuts in place.
- Ensure pulleys are properly aligned. Refer to *Figure 4*.

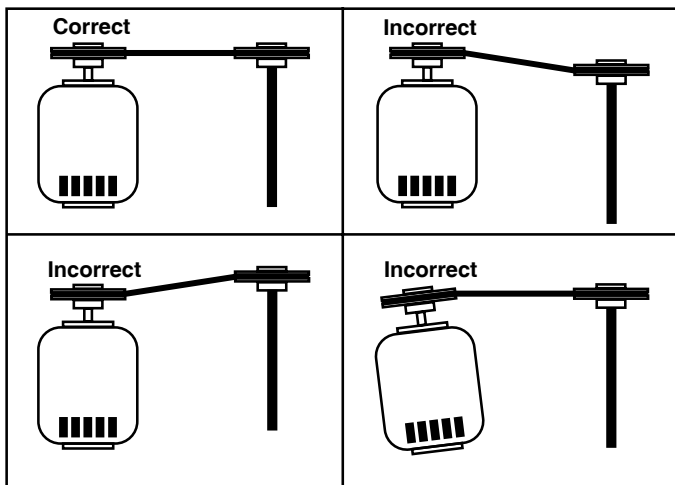

Figure 4

Pulley Alignment

Pulley alignment is adjusted by loosening the motor pulley setscrew and by moving the motor pulley on the motor shaft or by moving the entire motor along the motor mounting bracket.

Figure 4 illustrates correct and incorrect pulley alignment. A recommended method of inspecting the pulley alignment is shown in *Figure 5*. With the shorter leg of a carpenter's square or other straight edge lying along the case of the motor, adjust the position of the motor pulley (or the motor until the longer leg of the square is parallel to the belt.

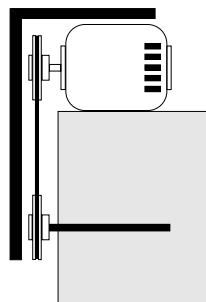

Figure 5

Final Installation Steps

- Inspect fasteners and setscrews, particularly fan mounting and bearing fasteners, and tighten according to the recommended torque shown in the table *Recommended Torque for Setscrews/Bolts*.
- Inspect for correct voltage with voltmeter.
- Ensure all accessories are installed.

Operation

Pre-Start Checks

- Lock out all the primary and secondary power sources.
- Ensure fasteners and setscrews, particularly those used for mounting the fan, are tightened.
- Inspect belt tension and pulley alignment.
- Inspect motor wiring.
- Ensure belt touches only the pulleys.
- Ensure fan and ductwork are clean and free of debris.
- Inspect wheel-to-inlet clearance. The correct wheel-to-inlet clearance is critical to proper fan performance.
- Close and secure all access doors.
- Restore power to the fan.

Recommended Torque for Setscrews/Bolts (IN/LB.)

Setscrews				Hold Down Bolts	
Size	Key Hex Across Flats	Recommended Torque		Size	Wrench Torque
		Min.	Max.		
No.10	3/32"	28	33	3/8"-16	240
1/4"	1/8"	66	80	1/2"-13	600
5/16"	5/32"	126	156	5/8"-11	1200
3/8"	3/16"	228	275	3/4"-10	2100
7/16"	7/32"	348	384	7/8"- 9	2040
1/2"	1/4"	504	600	1"- 8	3000
5/8"	5/16"	1104	1200	1-1/8" - 7	4200
3/4"	3/8"	1440	1800	1-1/4" - 7	6000

Start Up

Turn the fan on. In variable speed units, set the fan to its lowest speed and inspect for the following:

- Direction of rotation.
- Excessive vibration.
- Unusual noise.
- Bearing noise.
- Improper belt alignment or tension (listen for squealing).
- Improper motor amperage or voltage.

If a problem is discovered, immediately shut the fan off. Lock out all electrical power and check for the cause of the trouble. See Troubleshooting.

Inspection

Inspection of the fan should be conducted at the first **30 minute, 8 hour and 24 hour** intervals of satisfactory operation. During the inspections, stop the fan and inspect as per the *Conditions Chart*.

30 Minute Interval

Inspect bolts, setscrews, and motor mounting bolts. Adjust and tighten as necessary.

Wiring Diagrams

Single Speed, Single Phase Motor

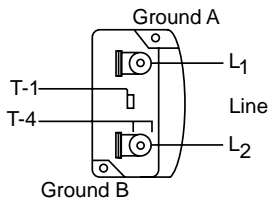

When ground is required, attach to ground A or B with no. 6 thread forming screw. To reverse, interchange T-1 and T-4.

2 Speed, 2 Winding, Single Phase Motor

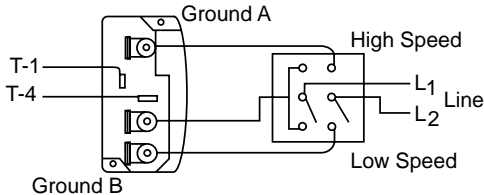

When ground required, attach to ground A or B with No. 6 thread forming screw. To reverse, interchange T-1 and T-4 leads.

Single Speed, Single Phase, Dual Voltage

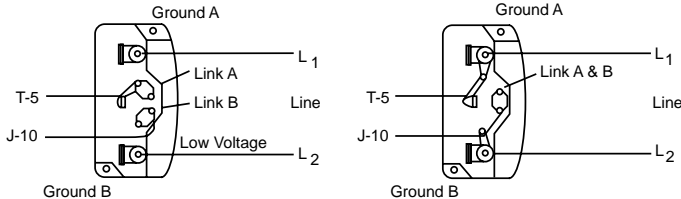

When ground required, attach to ground A or B with No. 6 thread forming screw. To reverse, interchange T-5 and J-10 leads.

Typical Damper Motor Schematic

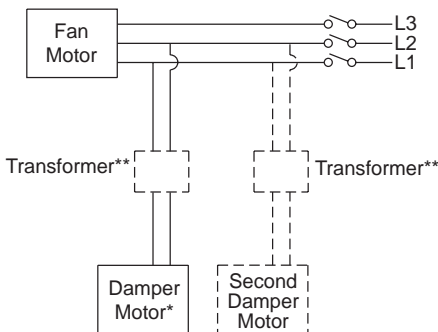

For 3 phase, damper motor voltage should be the same between L₁ and L₂. For single phase application, disregard L₃. *Damper motors may be available in 115, 230 and 460 volt models. The damper motor nameplate voltage should be verified prior to connection. ** A transformer may be provided in some installations to correct the damper motor voltage to the specified voltage.

8 Hour Interval

Inspect belt alignment and tension. Adjust and tighten as necessary.

24 Hour Interval

Inspect belt tension, bolts, setscrews, and motor mounting bolts. Adjust and tighten as necessary.

Maintenance

Establish a schedule for inspecting all parts of the fan. The frequency of inspection depends on the operating conditions and location of the fan.

Inspect fans exhausting corrosive or contaminated air within the first month of operation. Fans exhausting contaminated air (airborne abrasives) should be inspected every three months.

Regular inspections are recommended for fans exhausting non-contaminated air.

Wiring Diagrams

3 Phase, 9 Lead Motor Y-Connection

Low Voltage
208/230 Volts

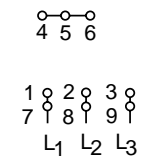

High Voltage
460 Volts

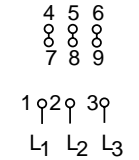

3 Phase, 9 Lead Motor Delta-Connection

Low Voltage
208/230 Volts

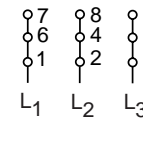

High Voltage
460 Volts

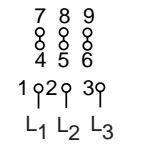

To reverse, interchange any 2 line leads.

2 Speed, 1 Winding, 3 Phase Motor

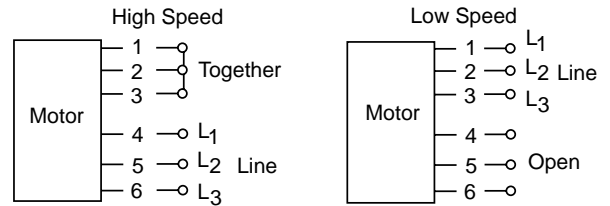

To reverse, interchange any 2 line leads. Motors require magnetic control.

2 Speed, 2 Winding, 3 Phase

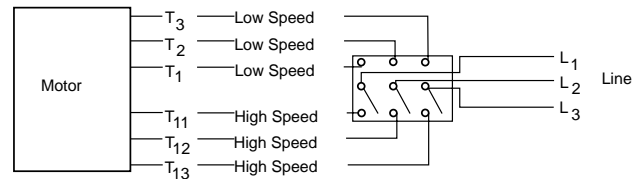

To reverse: High Speed-interchange leads T₁₁ and T₁₂. Low Speed-interchange leads T₁ and T₂. Both Speeds-interchange any 2 line leads.

It is recommended the following inspection be conducted twice per year.

- Inspect bolts and setscrews for tightness. Tighten as necessary. Worn setscrews should be replaced immediately.
- Inspect belt wear and alignment. Replace worn belts with new belts and adjust alignment as needed. See *Belt and Pulley Installation*, page 3.
- Bearings should be inspected as recommended in the *Conditions Chart*.
- Inspect variable inlet vanes for freedom of operation and excessive wear. The vane position should agree with the position of the control arm. As the variable inlet vanes close, the entering air should spin in the same direction as the wheel.
- Inspect springs and rubber isolators for deterioration and replace as needed.

Maintenance continued

- Inspect for cleanliness. Clean exterior surfaces only. Removing dust and grease on motor housing assures proper motor cooling. Removing dirt from the wheel and housing prevent imbalance and damage.

Conditions Chart			
RPM	Temperature	Fan Status	Greasing Interval
100	Up to 120°F	Clean	6 to 12 months
500	Up to 150°F	Clean	2 to 6 months
1000	Up to 210°F	Clean	2 weeks to 2 months
1500	Over 210°F	Clean	Weekly
Any Speed	Up to 150°F	Dirty	1 week to 1 month
Any Speed	Over 150°F	Dirty	Daily to 2 weeks
Any Speed	Any Temperature	Very Dirty	Daily to 2 weeks
Any Speed	Any Temperature	Extreme Conditions	Daily to 2 weeks

Lubricants

Loren Cook Company uses petroleum lubricant in a lithium base. Other types of grease should not be used unless the bearings and lines have been flushed clean. If another type of grease is used, it should be a lithium-based grease conforming to NLGI grade 2 consistency.

A NLGI grade 2 grease is a light viscosity, low-torque, rust-inhibiting lubricant that is water resistant. Its temperature range is from -30°F to +200°F and capable of intermittent highs of +250°F.

Motor Bearings

Motor bearings are pre-lubricated and sealed. Under normal conditions they will not require further maintenance for a period of ten years. However, it is advisable to have your maintenance department remove and disassemble the motor, and lubricate the bearings after three years of operation in excessive heat and or in a contaminated airstream consisting of airborne abrasives.

Fan Bearings

Greasable fan bearings are lubricated through a grease fitting on the bearing and should be lubricated by the schedule, *Conditions Chart*.

For best results, lubricate the bearing while the fan is in operation. Pump grease in slowly until a slight bead forms around the bearing seals. Excessive grease can burst seals thus reducing bearing life.

In the event the bearing cannot be seen, use no more than three injections with a hand-operated grease gun.

Motor Services

Should the motor prove defective within a one-year period, contact your local Loren Cook representative or your nearest authorized electric motor service representative.

Changing Shaft Speed

All belt driven fans with motors up to and including 5 HP (184T max.) are equipped with variable pitch pulleys. To change the fan speed, perform the following:

- Loosen setscrew on driver (motor) pulley and remove key, if equipped.
- Turn the pulley rim to open or close the groove facing. If the pulley has multiple grooves, all must be adjusted to the same width.
- After adjustment, inspect for proper belt tension.

Speed Reduction

Open the pulley in order that the belt rides deeper in the groove (smaller pitch diameter).

Speed Increase

Close the pulley in order that the belt rides higher in the groove (larger pitch diameter). Ensure that the RPM limits of the fan and the horsepower limits of the motor are maintained.

Pulley and Belt Replacement

- Remove pulleys from their respective shafts.
- Clean the motor and fan shafts.
- Clean bores of pulleys and coat the bores with heavy oil.
- Remove grease, rust, or burrs from the pulleys and shafts.
- Remove burrs from shaft by sanding.
- Place fan pulley on fan shaft and motor pulley on its shaft. Damage to the pulleys can occur when excessive force is used in placing the pulleys on their respective shafts.
- Tighten in place.
- Install belts on pulleys and align as described in the *Belt and Pulley Installation* section.

Bearing Replacement

The fan bearings are pillow block ball bearings.

An emery cloth or file may be needed to remove imperfections in the shaft left by the setscrews.

Arrangement 10

- Mark the position on the shaft of both bearing races, setscrews, and the wheel and pulley. Mark the location and orientation of the inlet cone. Note the clearance between the wheel and inlet cone.
- Remove the fan pulley.
- Remove the inlet cone.
- Remove the wheel from the shaft. A 2-jaw puller may be needed.
- Remove bearing hold-down bolts. Remove shaft and bearings as one unit.
- Remove the anti-corrosion coating from the shaft with a suitable degreaser.
- Remove the bearing from the shaft using a bearing puller. If a bearing puller is not available, tap on the bearing with a wood block and hammer to remove it.
- Smooth and clean the shaft and bearing bore thoroughly.
- Place the bearings into position making sure they are not on a worn section of the shaft. Tapping the inner ring face with a soft driver may be required. **Do not hammer on the housing.**

Arrangement 10 continued

- j. The outer ring of the bearing is spherical and swivels in the housing to compensate for misalignment. Secure hold-down bolts, but **do not fully tighten**.
- k. Align the setscrews on the bearings and tighten one setscrew on each bearing.
- l. Rotate the shaft to allow the bearing outer rings to find their center of free movement.
- m. Install the wheel on the shaft. Install the inlet cone in its original location. And adjust bearing position and inlet cone to center the wheel in the inlet cone.
- n. Tighten hold-down bolts to proper torque.
- o. Turn the shaft by hand. Resistance should be the same as it was before hold-down bolts were fully tightened.
- p. Tighten bearing setscrews to specified torque. Refer to Torque chart.
- q. Re-install the pulley and adjust the belt tension.
- r. Test run and retighten all setscrews and bolts; trim balance as necessary (.0785 in/sec max.).

After 24 hours of operation, retighten the setscrews to the appropriate torque. This assures full locking of the inner race to the shaft. Make sure the socket key or driver is in good condition with no rounded corners. The key should be fully engaged in the setscrew and held squarely to prevent rounding out of the setscrew socket when applying maximum torque.

Troubleshooting

Problem and Potential Cause
Low Capacity or Pressure <ul style="list-style-type: none">•Incorrect direction of rotation. Make sure the fan rotates in same direction as the arrows on the motor or belt drive assembly.•Poor fan inlet conditions. There should be a straight clear duct at the inlet.•Improper wheel alignment.
Excessive Vibration and Noise <ul style="list-style-type: none">•Damaged or unbalanced wheel.•Belts too loose; worn or oily belts.•Speed too high.•Incorrect direction of rotation. Make sure the fan rotates in same direction as the arrows on the motor or belt drive assembly.•Bearings need lubrication or replacement.•Fan surge or incorrect inlet or outlet condition.
Overheated Motor <ul style="list-style-type: none">•Motor improperly wired.•Incorrect direction of rotation. Make sure the fan rotates in same direction as the arrows on the motor or belt drive assembly.•Cooling air diverted or blocked.•Improper inlet clearance.•Incorrect fan RPMs.•Incorrect voltage.
Overheated Bearings <ul style="list-style-type: none">•Improper bearing lubrication•Excessive belt tension.

Series BI Parts List

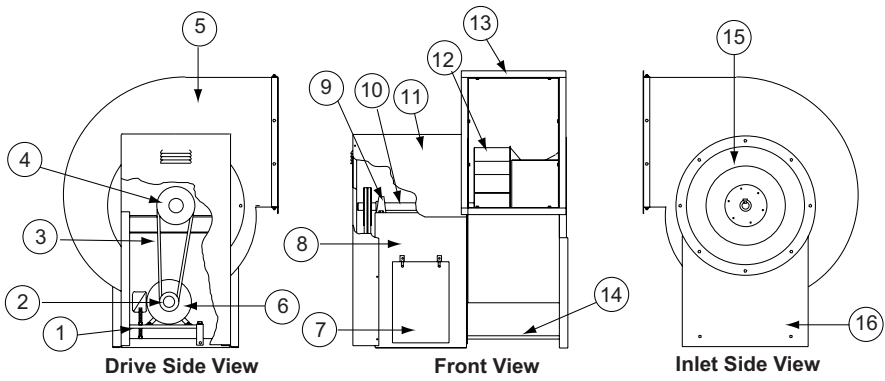

Part No.	Description
1	Motor Mount
2	Motor Sheave
3	Belt Set
4	Fan Sheave
5	Housing
6	Motor
7	Optional Side Cover (2)
8	Pedestal
9	Bearings (2)
10	Shaft
11	Optional Weather Cover
12	Wheel Assembly
13	Discharge Flange
14	Spreader Bar (2)
15	Inlet Cone
16	Inlet Side Support

MONOXIVENT
MONOXIVENT INC.
 1306 Mill Street
 ROCK ISLAND, IL 61201 USA
 (309) 794-1000 • FAX (309) 794-1020

SERIES BI IOM - January 2007